

NOTE:
ALL MANHOLE COLLAR NOTES APPLY

WATERVALVE

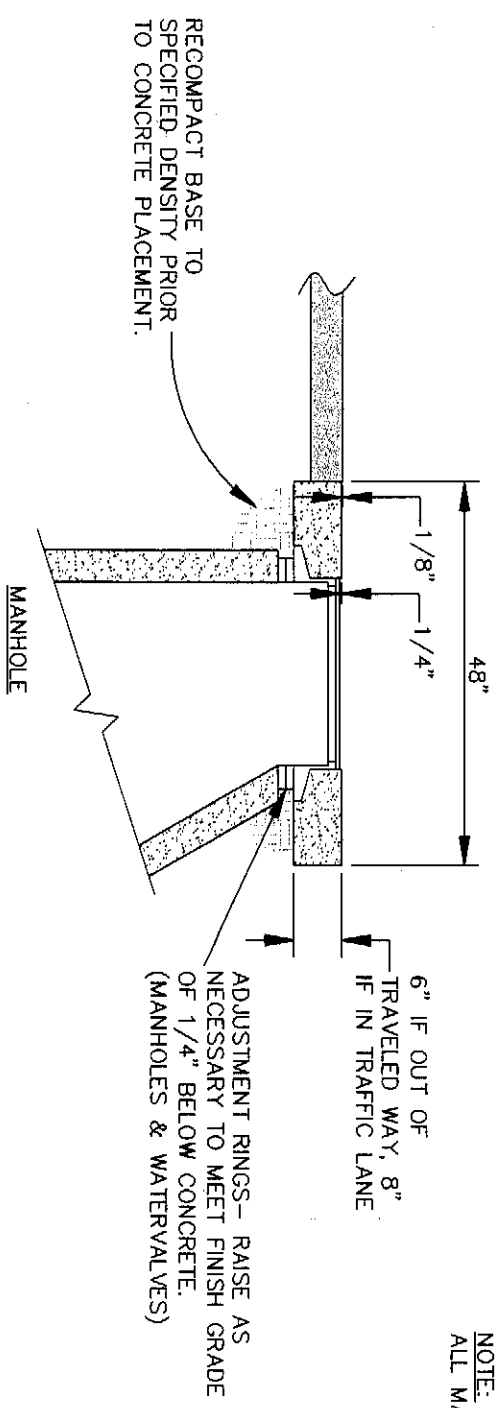

STREET AND CONCRETE
CONSTRUCTION STANDARDS

TOWN OF PONCHA SPRINGS, COLORADO
DEPARTMENT OF PUBLIC WORKS

CONCRETE
COLLAR DETAILS

DEL-MONT CONSULTANTS, INC.
MONTROSE, COLORADO
970-249-2251 - FAX 970-249-2342

APPROVED: _____
ADOPTED: _____
REVISD: _____
REVISD: _____
FILE NAME: 01194-DET.DWG

DATE: 8/23/02 DWG. No: _____